

GHD Series

Direct Drive Oil-Sealed Rotary Vacuum Pumps

High Speed type

GHD-060



With built-in thermal protector

GHD Series

Direct Drive Oil-Sealed Rotary Vacuum Pumps

High Speed type

GHD-120

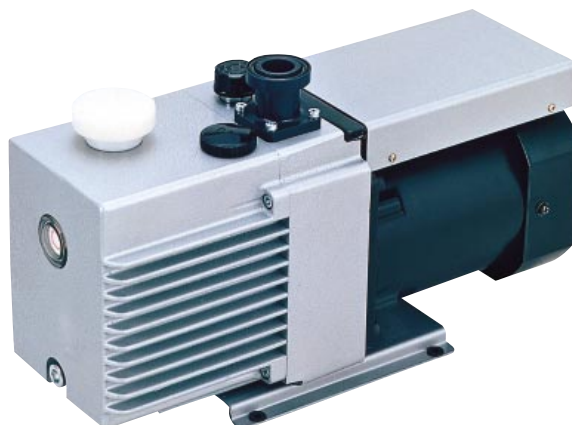

With built-in thermal protector

Outline drawing

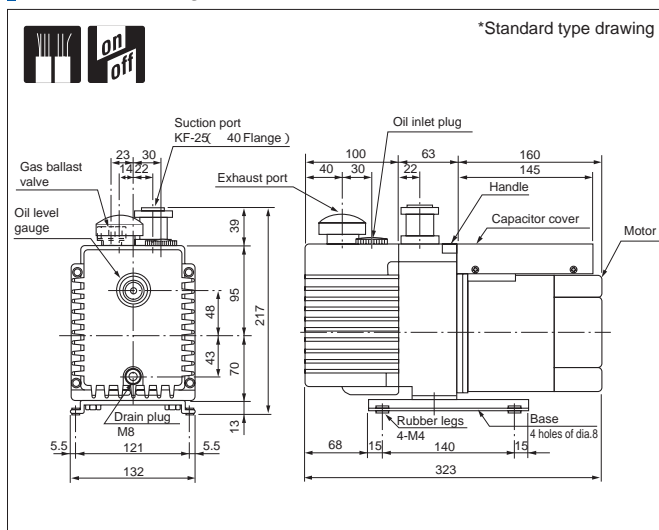

Outline drawing

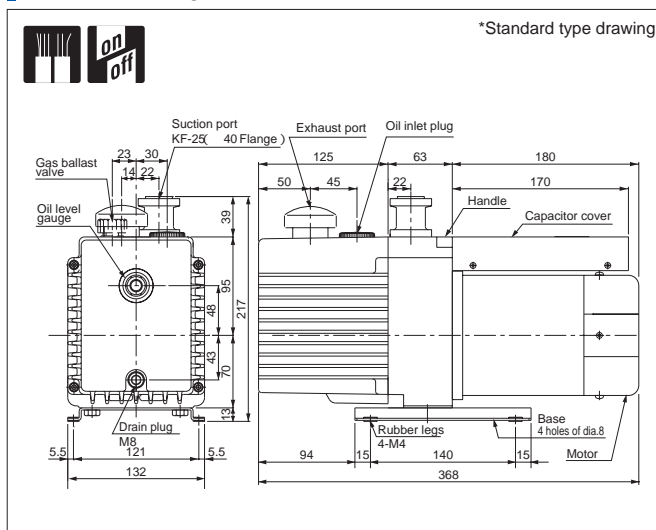

Specifications

	Unit	50Hz	60Hz
Actual pumping speed	L/min.	60	72
Ultimate pressure	G.V. Closed	6.7×10^{-2} (6.7×10^{-1})	
	G.V. Open		
Motor		Single phase, 100V, 200W, 2 poles, capacitor run	
Full load current	A	5.0	4.5
Oil capacity	mL	600	
Recommended oil		R-2	
Weight	kg	14	
Inlet port diameter	mm	KF-25	
Admissible temp range	°C	7 - 40	
Dimensions	mm	132(W) x 323(L) x 217(H)	

Specifications

	Unit	50Hz	60Hz
Actual pumping speed	L/min.	120	144
Ultimate pressure	G.V. Closed	6.7×10^{-2} (6.7×10^{-1})	
	G.V. Open		
Motor		Single phase, 100V, 300W, 2 poles, capacitor run	
Full load current	A	5.5	5.0
Oil capacity	mL	600	
Recommended oil		R-2	
Weight	kg	17	
Inlet port diameter	mm	KF-25	
Admissible temp range	°C	7 - 40	
Dimensions	mm	132(W) x 367(L) x 217(H)	