

G Series

Direct Drive Oil-Sealed Rotary Vacuum Pumps

Standard type

G-5DA



With built-in thermal protector

G Series

Direct Drive Oil-Sealed Rotary Vacuum Pumps

Standard type

G-10DA



With built-in thermal protector

Outline drawing

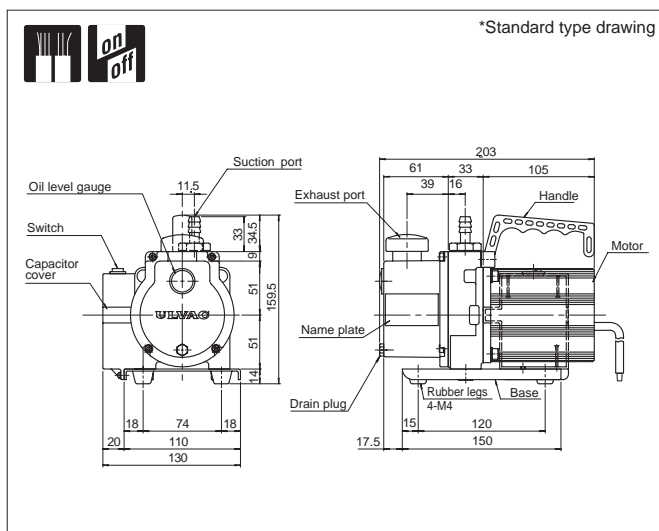

Outline drawing

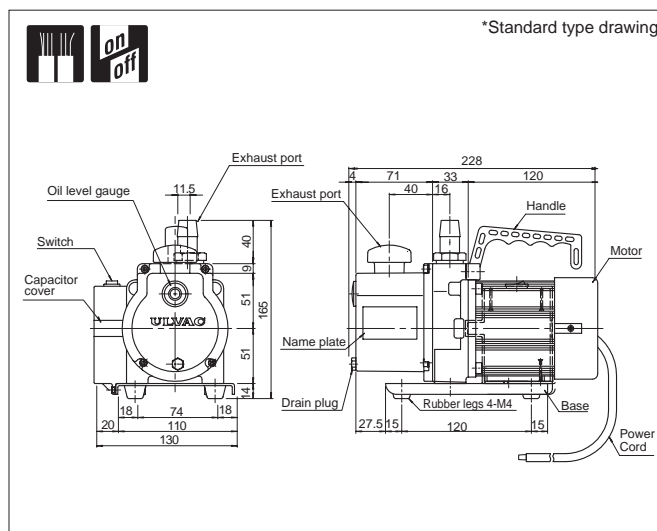

Specifications

	Unit	50Hz	60Hz
Actual pumping speed	L/min.	5	6
Ultimate pressure	Pa	6.7	
Motor		Single phase, 220V, 40W, 4 poles, capacitor run	
Full load current	A	0.42	0.35
Oil capacity	mL	180	
Recommended oil		SMR-100	
Weight	kg	5	
Inlet port diameter	mm	O.D. dia. 12 x I.D. dia. 6	
Admissible temp range	°C	7 - 40	
Dimensions	mm	130(W) x 203(L) x 159.5(H)	

Specifications

	Unit	50Hz	60Hz
Actual pumping speed	L/min.	10	12
Ultimate pressure	Pa	1.3	
Motor		Single phase, 220V, 60W, 4 poles, capacitor run	
Full load current	A	0.52	0.56
Oil capacity	mL	250	
Recommended oil		SMR-100	
Weight	kg	5.5	
Inlet port diameter	mm	O.D. dia. 18 x I.D. dia. 14	
Admissible temp range	°C	7 - 40	
Dimensions	mm	130(W) x 228(L) x 165(H)	

Optional voltage

Voltage	Applicable Volt	CE Marked	cTUVus Marked
Single phase, 100V	Standard	—	—
Single phase, 115V (60Hz)	●	—	—
Single phase, 220V	●	—	—

Optional voltage

Voltage	Applicable Volt	CE Marked	cTUVus Marked
Single phase, 100V	Standard	—	—
Single phase, 115V (60Hz)	●	—	—
Single phase, 220V (50Hz)	●	—	—

Ultimate pressure is measured with Macleod gauge.