

DTU Series

Diaphragm Type Dry Vacuum Pump

High Vacuum anti-corrosive type

DTU-20



With built-in thermal protector

DTC Series

Diaphragm Type Dry Vacuum Pump

Chemical type

DTC-21



With built-in thermal protector



Outline drawing

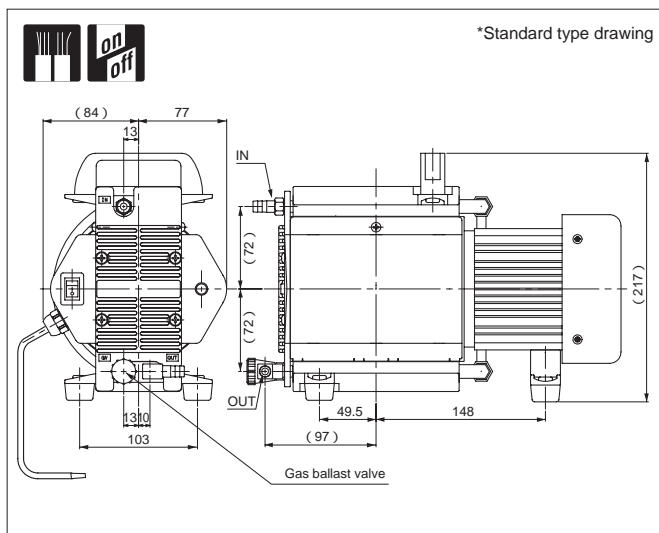

Specifications

	Unit	DTU-20
Actual Pumping Speed	L/min.	20/23 (50/60Hz)
Ultimate pressure	Pa	200
Motor		Single phase, 220V, 80W, 4P, Capacitor run
Full load current	A	0.70/0.72 (50/60Hz)
Weight	kg	7.5
Inlet, outlet pipe diameter	mm	O.D. dia.10 x I.D.dia.6 (RC1/8)
Admissible temp range	°C	5 - 40
Dimensions	mm	161(W) x 327(L) x 218(H)

Optional voltage

Voltage	Applicable Volt	CE Marked	cTUVus Marked
Single phase, 100V	Standard	—	—
Single phase, 115V	●	—	—
Single phase, 200V	●	—	—
Single phase, 220V	●	—	—

Outline drawing

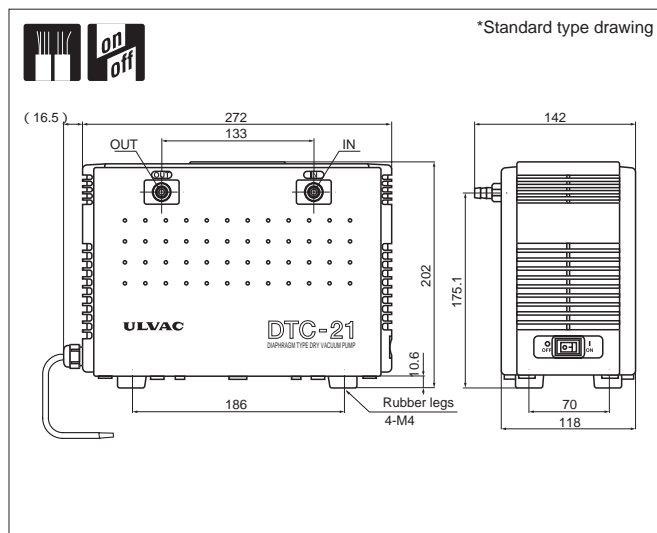

Specifications

	Unit	DTC-21D	
Actual Pumping Speed	L/min	20/24 (50/60Hz)	
Ultimate pressure	Pa	1.0 x 10 ³	
Motor		Single phase, 220V, 50W, 4P, Capacitor run	
Full load current	A	0.69/0.65 (50/60Hz)	
Weight	kg	7.3	7.2
Inlet, outlet pipe diameter	mm	O.D. dia.9 x I.D. dia.5 (G1/4)	
Admissible temp range	°C	0 - 40	
Dimensions	mm	142(W) x 288.5(L) x 202(H)	125(W) x 242(L) x 184(H)

Optional voltage

Voltage	Model	Applicable Volt	CE Marked	cTUVus Marked
Single phase, 100V	DTC-21A	Standard	●	●
Single phase, 230V	DTC-21B	●	●	●
Single phase, 115V	DTC-21C	●	●	●
Single phase, 220V	DTC-21D	●	●	●