

DAT Series

Diaphragm Type Dry Vacuum Pump

Standard type

DAT-50D

RoHS compliant



With built-in thermal protector

DAT Series

Diaphragm Type Dry Vacuum Pump

Standard type

DAT-100S

RoHS compliant



With built-in thermal protector

Outline drawing

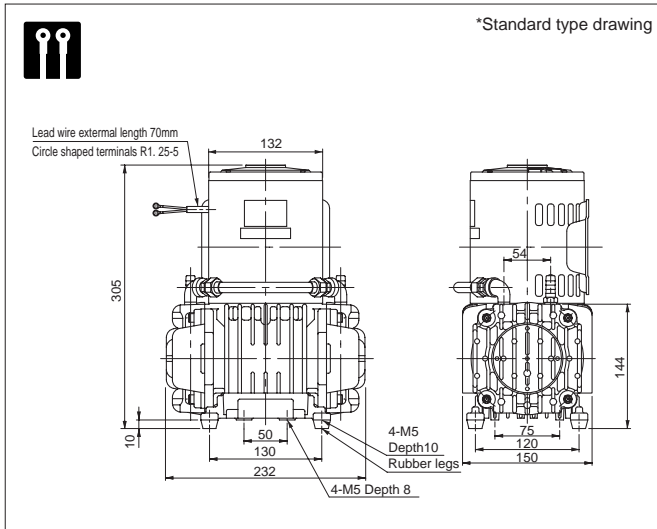

Outline drawing

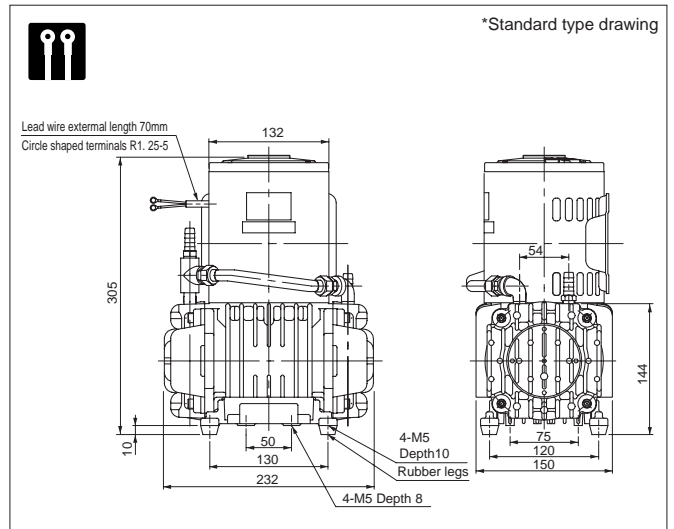

Specifications

| | Unit | DAT-50D |
|-----------------------------|--------|--|
| Actual Pumping Speed | L/min. | 50/55 (50/60Hz) |
| Ultimate pressure | Pa | 3.3×10^3 |
| Motor | | Single phase, 220V, 200W, 4P, Split phase starting |
| Full load current | A | 2.6/2.2 (50/60Hz) |
| Weight | kg | 11.0 |
| Inlet, outlet pipe diameter | mm | O.D. dia.12 x I.D.dia.8 (Rc 1/4) |
| Admissible temp range | °C | 7 - 40 |
| Dimensions | mm | 150(W) x 232(L) x 305(H) |

Specifications

| | Unit | DAT-100S |
|-----------------------------|--------|--|
| Actual Pumping Speed | L/min. | 100/110 (50/60Hz) |
| Ultimate pressure | Pa | 13.3×10^3 |
| Motor | | Single phase, 220V, 200W, 4P, Split phase starting |
| Full load current | A | 2.6/2.2 (50/60Hz) |
| Weight | kg | 11.0 |
| Inlet, outlet pipe diameter | mm | O.D. dia.12 x I.D.dia.8 (Rc 1/4) |
| Admissible temp range | °C | 7 - 40 |
| Dimensions | mm | 150(W) x 232(L) x 305(H) |

Optional voltage

| Voltage | Applicable Volt | CE Marked | cTUVus Marked |
|--------------------|-----------------|-----------|---------------|
| Single phase, 100V | Standard | — | — |
| Single phase, 115V | ● | — | — |
| Single phase, 200V | ● | — | — |
| Single phase, 220V | ● | — | — |

Optional voltage

| Voltage | Applicable Volt | CE Marked | cTUVus Marked |
|--------------------|-----------------|-----------|---------------|
| Single phase, 100V | Standard | — | — |
| Single phase, 115V | ● | — | — |
| Single phase, 200V | ● | — | — |
| Single phase, 220V | ● | — | — |