

**DA Series**  
**Diaphragm Type Dry Vacuum Pump**  
 Standard type  
**DA-121D**

RoHS compliant



With built-in thermal protector

**DA Series**  
**Diaphragm Type Dry Vacuum Pump**  
 Standard type  
**DA-241S**

RoHS compliant



With built-in thermal protector

**Outline drawing**

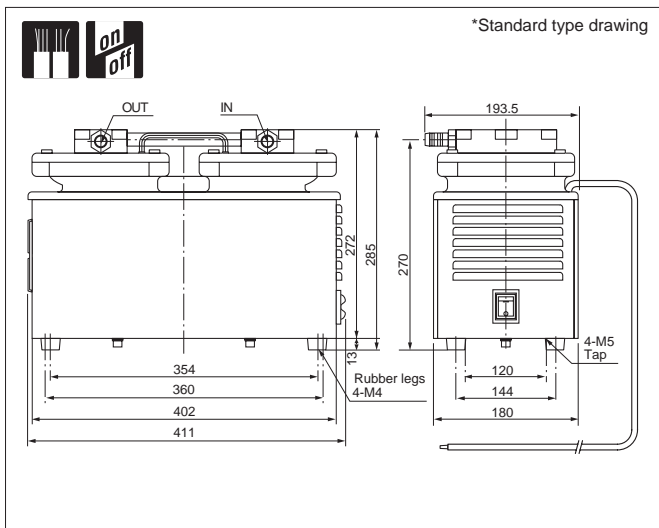

**Outline drawing**

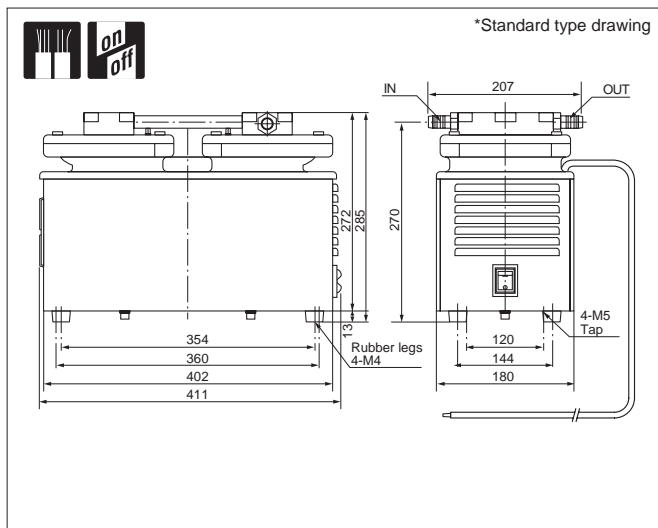

**Specifications**

	Unit	DA-121D
Actual Pumping Speed	L/min.	120/145 (50/60Hz)
Ultimate pressure	Pa	$3.3 \times 10^3$
Motor		Single phase, 220V, 400W, 4P, Capacitor run
Full load current	A	3.0
Weight	kg	26.0
Inlet, outlet pipe diameter	mm	O.D. dia.16 x I.D.dia.12 (G1/2)
Admissible temp range	°C	0 – 40
Dimensions	mm	193.5(W) x 411(L) x 285(H)

**Specifications**

	Unit	DA-241S
Actual Pumping Speed	L/min.	240/260 (50/60Hz)
Ultimate pressure	Pa	$16.0 \times 10^3$
Motor		Single phase, 220V, 400W, 4P, Capacitor run
Full load current	A	3.0
Weight	kg	26.0
Inlet, outlet pipe diameter	mm	O.D. dia.16 x I.D.dia.12 (G1/2)
Admissible temp range	°C	0 – 40
Dimensions	mm	207(W) x 411(L) x 285(H)

**Optional voltage**

Voltage	Applicable Volt	CE Marked	cTUVus Marked
Single phase, 100V	Standard	●	—
Single phase, 115V	●	—	—
Single phase, 200V	●	●	—
Single phase, 220V	●	—	—

**Optional voltage**

Voltage	Applicable Volt	CE Marked	cTUVus Marked
Single phase, 100V	Standard	●	—
Single phase, 115V	●	—	—
Single phase, 200V	●	●	—
Single phase, 220V	●	—	—