

DA Series

Diaphragm Type Dry Vacuum Pump

Standard type

DA-120S



With built-in thermal protector/Unloader valve

DA Series

Diaphragm Type Dry Vacuum Pump

Standard type

DA-121D



CE

With built-in thermal protector

Outline drawing

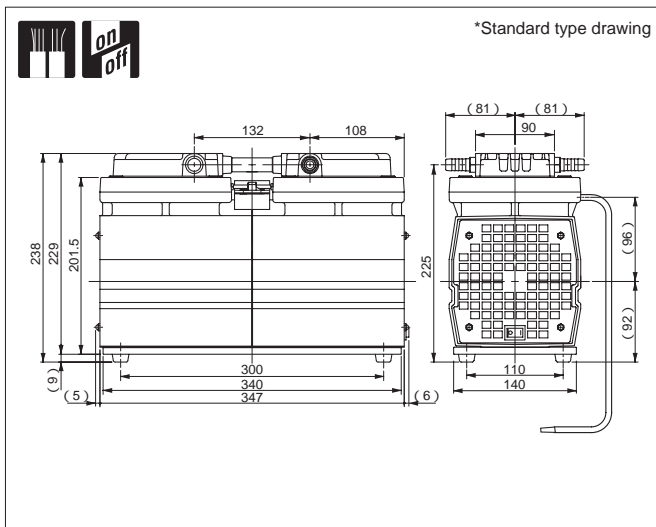

Outline drawing

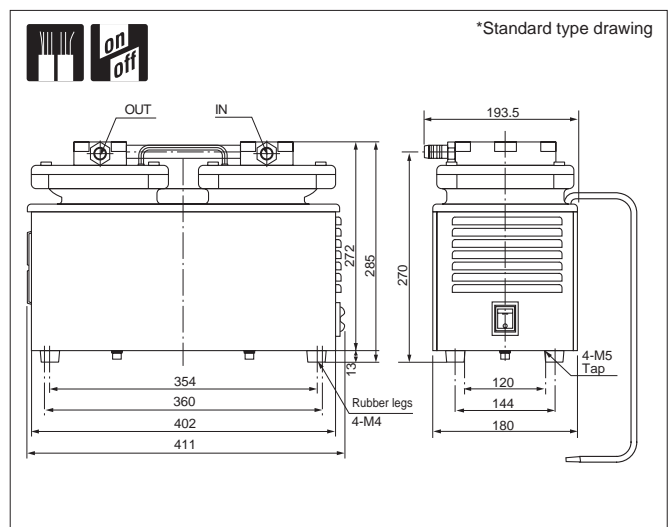

Specifications

	Unit	DA-120S
Actual Pumping Speed	L/min.	120/144 (50/60Hz)
Ultimate pressure	Pa	13.3×10^3
Motor		Single phase, 220V, 200W, 4P, Capacitor run
Full load current	A	2.4
Weight	kg	19.0
Inlet, outlet pipe diameter	mm	O.D. dia.14 x I.D.dia.9 (G3/8)
Admissible temp range	°C	7 - 40
Dimensions	mm	162(W) x 347(L) x 238(H)

Specifications

	Unit	DA-121D
Actual Pumping Speed	L/min.	120/145 (50/60Hz)
Ultimate pressure	Pa	3.3×10^3
Motor		Single phase, 220V, 400W, 4P, Capacitor run
Full load current	A	3.0
Weight	kg	26.0
Inlet, outlet pipe diameter	mm	O.D. dia.16 x I.D.dia.12 (G1/2)
Admissible temp range	°C	0 - 40
Dimensions	mm	193.5(W) x 411(L) x 285(H)

Optional voltage

Voltage	Applicable Volt	CE Marked	cTUVus Marked
Single phase, 100V	Standard	—	—
Single phase, 115V	●	—	—
Single phase, 200V	●	—	—
Single phase, 220V	●	—	—

Optional voltage

Voltage	Applicable Volt	CE Marked	cTUVus Marked
Single phase, 100V	Standard	●	—
Single phase, 115V	●	—	—
Single phase, 200V	●	●	—
Single phase, 220V	●	—	—