

DA Series

Diaphragm Type Dry Vacuum Pump

Standard type

DA-81S/81SK



built-in type **DA-81SK**

With built-in thermal protector

DA Series

Diaphragm Type Dry Vacuum Pump

Standard type

DA-60D



With built-in thermal protector/Unloader valve

Outline drawing

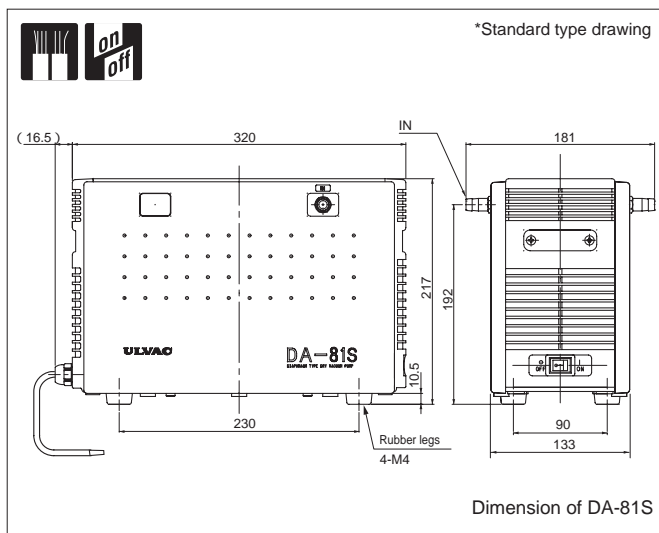

Outline drawing

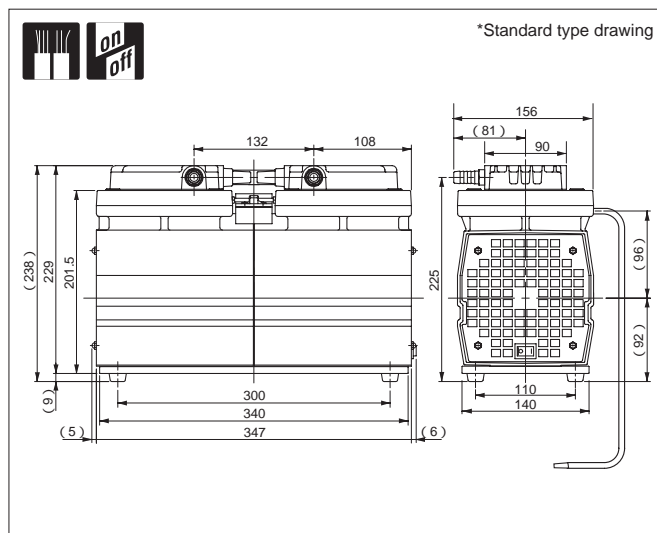

Specifications

| | Unit | DA-81S | DA-81SK |
|-----------------------------|--------|---|--------------------------|
| Actual Pumping Speed | L/min. | 75/85 (50/60Hz) | |
| Ultimate pressure | Pa | 13.3 x 10 ³ | |
| Motor | | Single phase, 220V, 100W, 4P, Capacitor run | |
| Full load current | A | 1.1 | |
| Weight | kg | 10.3 | 10.2 |
| Inlet, outlet pipe diameter | mm | O.D. dia.12 x I.D.dia.8 (G1/4) | |
| Admissible temp range | °C | 0 - 40 | |
| Dimensions | mm | 181(W) x 336.5(L) x 217(H) | 153(W) x 288(L) x 202(H) |

Specifications

| | Unit | DA-60D |
|-----------------------------|--------|---|
| Actual Pumping Speed | L/min. | 60/72 (50/60Hz) |
| Ultimate pressure | Pa | 3.32 x 10 ³ |
| Motor | | Single phase, 220V, 200W, 4P, Capacitor run |
| Full load current | A | 2.4 |
| Weight | kg | 19.0 |
| Inlet, outlet pipe diameter | mm | O.D. dia.14 x I.D.dia.9 (G3/8) |
| Admissible temp range | °C | 7 - 40 |
| Dimensions | mm | 156(W) x 347(L) x 238(H) |

Optional voltage

| Voltage | Applicable Volt | CE Marked | cTUVus Marked |
|--------------------|-----------------|-----------|---------------|
| Single phase, 100V | Standard | — | — |
| Single phase, 115V | ● | — | — |
| Single phase, 200V | ● | — | — |
| Single phase, 220V | ● | — | — |

Optional voltage

| Voltage | Applicable Volt | CE Marked | cTUVus Marked |
|--------------------|-----------------|-----------|---------------|
| Single phase, 100V | Standard | — | — |
| Single phase, 115V | ● | — | — |
| Single phase, 200V | ● | — | — |
| Single phase, 220V | ● | — | — |

DA-81SK is a built-in type of DA-81S.