

DA Series

Diaphragm Type Dry Vacuum Pump

Standard type

DA-30D

RoHS compliant

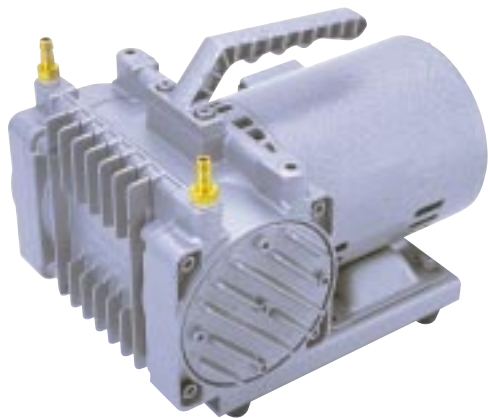

With built-in thermal protector

DA Series

Diaphragm Type Dry Vacuum Pump

Standard type

DA-60S

RoHS compliant

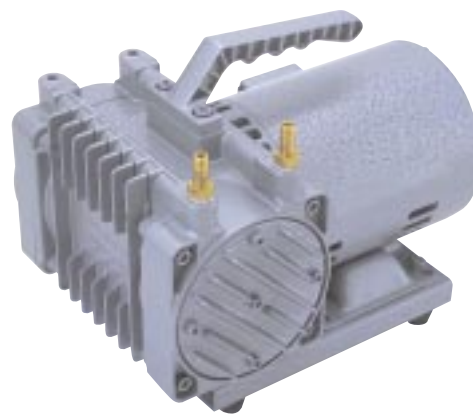

With built-in thermal protector

Outline drawing

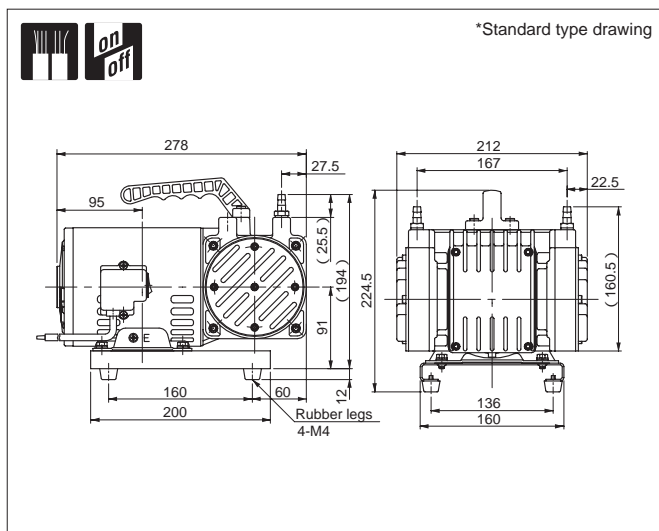

Specifications

	Unit	DA-30D
Actual Pumping Speed	L/min.	30/36 (50/60Hz)
Ultimate pressure	Pa	6.7×10^3
Motor		Single phase, 220V, 200W, 4P, Split phase starting
Full load current	A	2.6/2.2 (50/60Hz)
Weight	kg	11.0
Inlet, outlet pipe diameter	mm	O.D. dia.9 x I.D.dia.5 (Rc 1/4)
Admissible temp range	°C	7 - 40
Dimensions	mm	212(W) x 278(L) x 224.5(H)

Optional voltage

Voltage	Applicable Volt	CE Marked	cTUVus Marked
Single phase, 100V	Standard	—	—
Single phase, 115V	●	—	—
Single phase, 200V	●	—	—
Single phase, 220V	●	—	—

Outline drawing

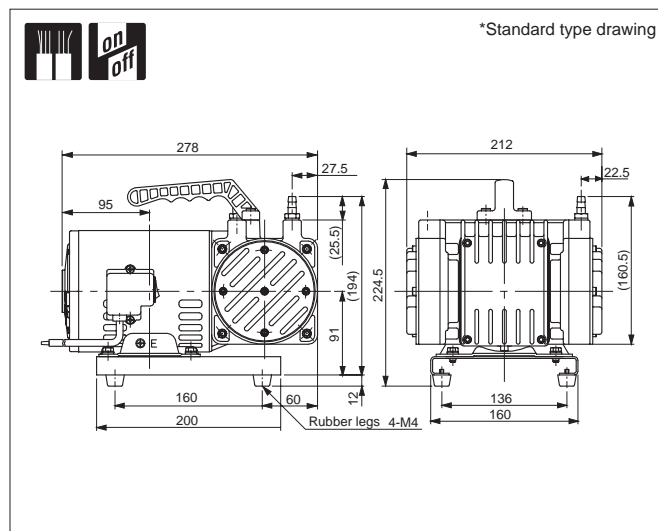

Specifications

	Unit	DA-60S
Actual Pumping Speed	L/min.	60/72 (50/60Hz)
Ultimate pressure	Pa	21.3×10^3
Motor		Single phase, 220V, 200W, 4P, Split phase starting
Full load current	A	2.6/2.2 (50/60Hz)
Weight	kg	11.0
Inlet, outlet pipe diameter	mm	O.D. dia.9 x I.D.dia.5 (Rc1/4)
Admissible temp range	°C	7 - 40
Dimensions	mm	212(W) x 278(L) x 224.5(H)

Optional voltage

Voltage	Applicable Volt	CE Marked	CSA Marked	cTUVus Marked
Single phase, 100V	Standard	—	—	—
Single phase, 115V	●	—	—	—
Single phase, 200V	●	—	—	—
Single phase, 220V	●	—	—	—