

**DA Series**
**Diaphragm Type Dry Vacuum Pump**

Standard type

**DA-20D**

RoHS compliant



With built-in thermal protector/Unloader valve (option)

**DA Series**
**Diaphragm Type Dry Vacuum Pump**

Standard type

**DA-40S**

RoHS compliant

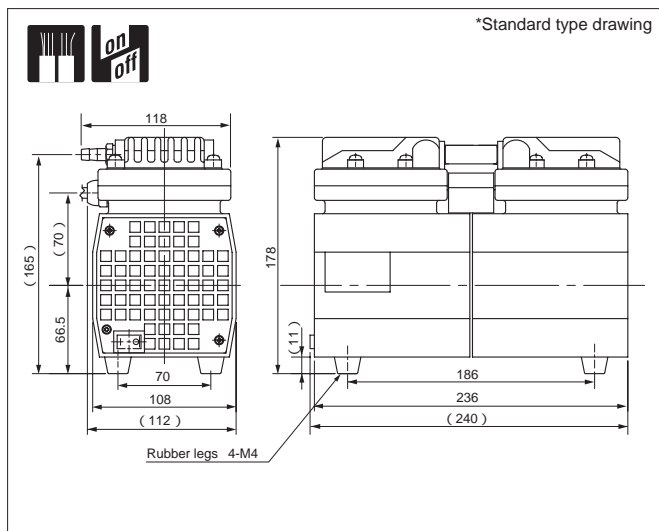
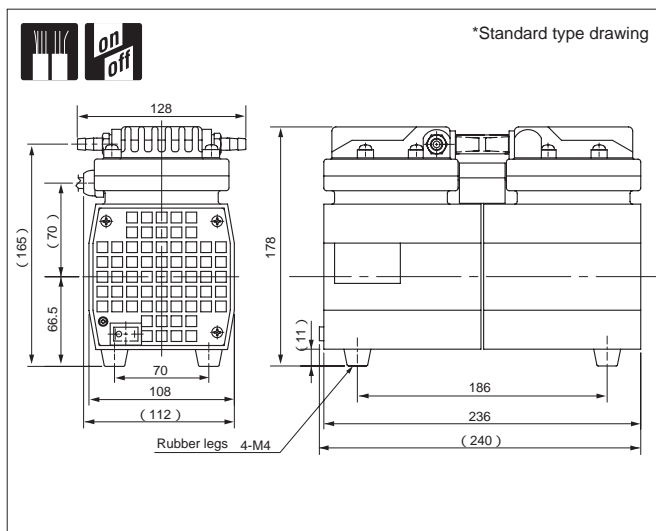

With built-in thermal protector/Unloader valve (option)

**Outline drawing**

**Outline drawing**

**Specifications**

	Unit	DA-20D
Actual Pumping Speed	L/min.	20/24 (50/60Hz)
Ultimate pressure	Pa	5.3 x 10 <sup>3</sup> with unloader valve 9.3 x 10 <sup>3</sup>
Motor		Single phase, 220V, 60W, 4P, Capacitor run
Full load current	A	0.60/0.58 (50/60Hz)
Weight	kg	7.2
Inlet, Outlet port diameter	mm	O.D. dia. 9 x I.D. dia. 5 (Rc 1/4)
Admissible temp range	°C	7 - 40
Dimensions	mm	118(W) x 240(L) x 178(H)

**Specifications**

	Unit	DA-40S
Actual Pumping Speed	L/min.	40/46 (50/60Hz)
Ultimate pressure	Pa	19.9 x 10 <sup>3</sup> with unloader valve 22.6 x 10 <sup>3</sup>
Motor		Single phase, 220V, 60W, 4P, Capacitor run
Full load current	A	0.60/0.58 (50/60Hz)
Weight	kg	7.2
Inlet, outlet pipe diameter	mm	O.D. dia. 9 x I.D. dia. 5 (Rc 1/4)
Admissible temp range	°C	7 - 40
Dimensions	mm	128(W) x 240(L) x 178(H)

**Optional voltage**

Voltage	Applicable Volt	CE Marked	cTUVus Marked
Single phase, 100V	Standard	—	—
Single phase, 115V	●	—	—
Single phase, 200V	●	—	—
Single phase, 220V	●	—	—

**Optional voltage**

Voltage	Applicable Volt	CE Marked	cTUVus Marked
Single phase, 100V	Standard	—	—
Single phase, 115V	●	—	—
Single phase, 200V	●	—	—
Single phase, 220V	●	—	—